

Tech Spec Guide



icpi

Interlocking Concrete
Pavement Institute®

Your requested ICPI Tech Spec **24** follows this page.

Design and Installation Professionals frequently turn to interlocking concrete pavements and permeable interlocking concrete pavements because they offer lower initial and life cycle costs and provide environmentally sustainable solutions.

ICPI provides resources for ICP and PICP design, construction, and maintenance. These include: Tech Specs, Guide Specs, Detail Drawings, Construction Tolerance Guides, Fact Sheets, Design Manuals and design software. ICPI also offers several relevant continuing education courses at icpi.org and aecdaily.com

Find the right guide for your location.

Many ICPI members subscribe by state or province to this Tech Spec service to support the development and revision of these technical documents. The ICPI website Technical Center offers the opportunity to select Tech Specs by state or province.

This ICPI Tech
Spec is
provided
courtesy of



<https://icpi.org/orcoblock>

ICPI Tech Spec Library

- **Tech Spec 1:** Glossary of Terms for Segmental Concrete Pavement
- **Tech Spec 2:** Construction of Interlocking Concrete Pavements
- **Tech Spec 3:** Edge Restraints for Interlocking Concrete Pavements
- **Tech Spec 4:** Structural Design of Interlocking Concrete Pavement for Roads and Parking Lots
- **Tech Spec 5:** Cleaning, Sealing and Joint Sand Stabilization of Interlocking Concrete Pavement
- **Tech Spec 6:** Reinstatement of Interlocking Concrete Pavements
- **Tech Spec 7:** Repair of Utility Cuts Using Interlocking Concrete Pavements
- **Tech Spec 8:** Concrete Grid Pavements
- **Tech Spec 9:** Guide Specification for the Construction of Interlocking Concrete Pavement
- **Tech Spec 10:** Application Guide for Interlocking Concrete Pavements
- **Tech Spec 11:** Mechanical Installation of Interlocking Concrete Pavements
- **Tech Spec 12:** Snow Melting Systems for Interlocking Concrete Pavements
- **Tech Spec 13:** Slip and Skid Resistance of Interlocking Concrete Pavements
- **Tech Spec 14:** Concrete Paving Units
- **Tech Spec 15:** A Guide for the Construction of Mechanically Installed Interlocking Concrete Pavements
- **Tech Spec 16:** Achieving LEED Credits with Segmental Concrete Pavement
- **Tech Spec 17:** Bedding Sand Selection for Interlocking Concrete Pavements in Vehicular Applications
- **Tech Spec 18:** Construction of Permeable Interlocking Concrete Pavement Systems
- **Tech Spec 19:** Design, Construction and Maintenance of Interlocking Concrete Pavement Crosswalks
- **Tech Spec 20:** Construction of Bituminous- Sand Set Interlocking Concrete Pavement
- **Tech Spec 21:** Capping and Compression Strength Testing Procedures for Concrete Pavers
- **Tech Spec 22:** Geosynthetics for Segmental Concrete Pavements
- **Tech Spec 23:** Maintenance Guide for Permeable Interlocking Concrete Pavements
- **Tech Spec 24:** Structural Design of Segmental Concrete Paving Slab and Plank Pavement Systems
- **Tech Spec 25:** Construction Guidelines for Segmental Concrete Paving Slabs and Planks in Non-Vehicular Residential Applications



Structural Design of Segmental Concrete Paving Slab and Plank Pavement Systems

Introduction

Project owners and designers specify segmental concrete paving slabs and planks due to their unique visual appeal and finishes. Their large or linear format often fits a particular dimensional module for the design of the project, complements the architectural character of adjacent buildings, or enhances the landscape architecture of the site. Some designers understate the visual pattern of a segmental pavement surface by using paving slabs with fewer joints. In other situations, designers may mix smaller and larger slab units to create strong visual effects. Planks or linear paving units are often used to suggest visual movement and direction. While most applications are for pedestrian uses, paving slabs and planks are seeing increased use in areas with vehicular traffic.

This technical bulletin provides structural design guidance on paving slabs and planks for at-grade applications. This Tech Spec introduces structural design tables that

provide guidance on maximum vehicular traffic loads for various unit sizes and thicknesses, as well as selected base materials and thicknesses. Roof applications using paving slabs for pedestrian applications is covered in *ICPI Tech Spec 14—Concrete Paving Units for Roof Decks*.

When properly designed and constructed, slab and plank pavement systems can withstand a *limited* amount of automobile and truck traffic. Unlike interlocking concrete pavements, slab and plank systems offer little to no vertical, horizontal or rotational interlock. They do not transfer applied loads to neighboring units, thereby limiting their application to areas with little traffic. Besides appropriate structural design provided in this bulletin, selection, testing, and installation of base and paving materials requires a high level of competency in order to assure successful performance. For areas with higher traffic loads than those provided in the design tables in this



Figure 1. Concrete paving slabs can create certain moods and enhance the character of a project.

technical bulletin, interlocking concrete pavement or permeable interlocking concrete pavement should be considered. Structural design for interlocking concrete pavement is covered in *ICPI Tech Spec 4* and in *ASCE 58-16 Structural Design of Interlocking Concrete Pavement for Municipal Streets and Roadways*. This *Tech Spec* and all others are available for free on www.icpi.org. Permeable interlocking concrete pavement structural design is covered in the ICPI manual, *Permeable Interlocking Concrete Pavements* and in *ASCE 68-18* with the same name.

Paving Slab Systems

Product Definitions—In the U.S. ASTM C1782 *Standard Specification for Utility Segmental Concrete Paving Slabs* defines their dimensional envelope as having an exposed face area greater than 101 in.² (0.065 m²) and a length divided by thickness greater than four. The minimum thickness is 1.2 in. (30 mm), and maximum length and width dimensions are 48 in. (1220 mm). C1782 was first issued by ASTM in 2016.

In Canada, CSA A231.1 *Precast Concrete Paving Slabs* defines the dimensional envelope with a face area greater than 139.5 in.² (0.09 m²) and a length divided by thickness of greater than four. The minimum thickness is 1.2 in. (30 mm), and the maximum length and width dimensions are 39.37 in. (1000 mm). This product standard was first issued by CSA in 1972.

Strength Requirements—Laboratory flexural or bending strength requirements are provided in ASTM C1782 and CSA A231.1 paving slab standards. Figure 2 illustrates the flexural strength test method. Laboratory tests for flexural or bending strength is determined by suspending the paving slab between two rollers and applying a load across the center until failure. The flexural strength

in pounds per square inch or megapascals is calculated using a modulus of rupture formula. A noteworthy aspect of the flexural strength formula is doubling the thickness of a paving slab increases the flexural (bending) strength by four times. This suggests that units may need increased thicknesses in order to withstand vehicular traffic. This need is addressed in the design tables presented later in this bulletin. In addition, concrete paving slabs may use fibers to increase their flexural strength.

ASTM C1782 and CSA A231.1 require an average minimum flexural strength of 725 psi (5 MPa) with no individual unit less than 650 psi (4.5 MPa). Unlike interlocking concrete pavers, compressive strength testing is not used to establish the strength of paving slabs. The reason for this is paving slabs are larger and often thinner than concrete pavers. If slabs are tested in compression, they will render a misleading higher compressive strength than concrete pavers. This principal applies to all concrete materials: as they become thinner, they render increased compressive strengths (while increasingly subject to failure in bending). The higher compressive strengths in slabs must be reduced to accurately compare that strength to a similar thickness and length of concrete pavers or other concrete products. Flexural strength testing for paving slabs provides a more realistic characterization of field conditions as the primary failure mode is bending which results in cracking from repeated vehicular wheel loads.

Freeze-thaw durability requirements in ASTM C1782 references ASTM C1645 *Standard Test Method for Freeze-thaw and De-icing Salt Durability of Solid Concrete Interlocking Paving Units*. This test method involves cutting coupons (test specimens) of a specified dimensional range from the corner of paving slabs. The coupons are immersed in water or a 3% saline solution and subjected up to 49 freeze-thaw cycles. The mass lost from the coupons are measured at

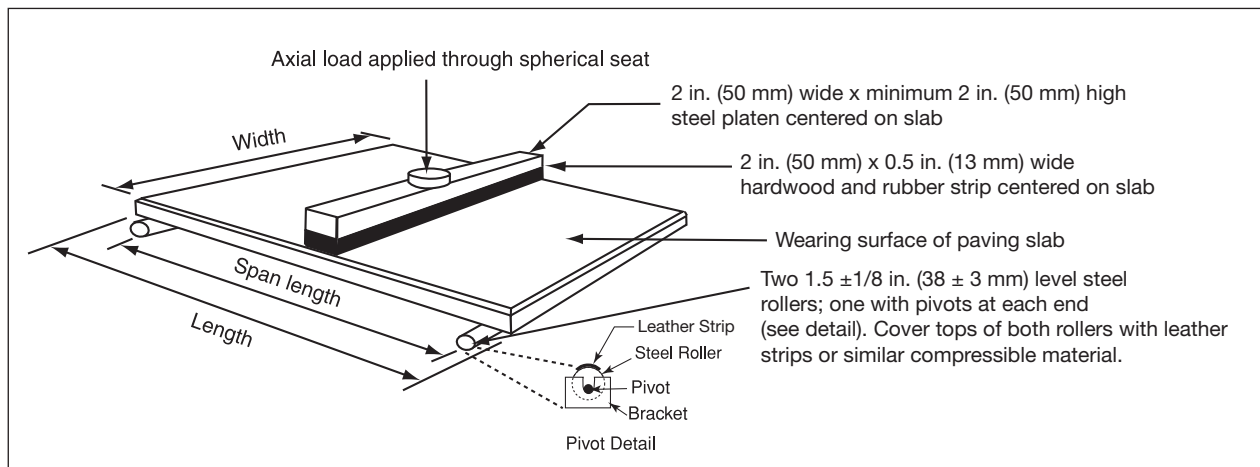

Figure 2. Flexural or bending test to determine the modulus of rupture.

28 and 49 cycles. If no more than an average of 225 grams per square meter of surface area are lost after 28 cycles, the paving slab passes this requirement in C1782. If not, the freeze-thaw cycles continue to a maximum of 49. If no more than an average of 500 grams per square meter of surface is lost after 49 cycles, the paving slab passes this requirement. The lowest temperature used in this freeze-thaw test is 23°F or -5° C. Figure 3 illustrates a test specimen in saline solution prepared for this test.

Freeze-thaw durability testing in CSA A231.1 is the same as in ASTM C1782. However, the lowest temperature in the CSA standard is 5° F or -15° C.

Dimensional tolerances are similar in ASTM and CSA paving slab standards. Dimensional tolerances are determined from unit dimensions provided by the manufacturer for specific products. Tolerances for length, width and height and for convex and concave warpage are as follows:

- Length and width: -0.04 and +0.08 in. (-1.0 and +2.0 mm)
- For units over 24 in. (610 mm), ASTM C1782 allows -0.06 and +0.12 in. (-1.5 and +3.0 mm)
- Height: ±0.12 in (±3.0 mm)
- Concave or convex warpage in units up to and including 18 in. (450 mm) in length or width: 0.08 in. (2.0 mm); units over 18 in. (450 mm): 0.12 in. (3.0 mm)

Paving slabs meeting these tolerances can be installed on a sand setting bed (i.e., sand-set) in residential applications, but are not suitable for more accurate sand-set, bitumen-set or pedestal-set deck commercial applications. These installation methods typically require length, width, thickness and warpage tolerances of ±0.06 in. (±1.5 mm) than the specified dimensions. In some cases, paving units may require post-production grinding to achieve these tolerances. This treatment is sometimes called gauging.

The Importance of Nomenclature

Segmental concrete paving slabs are sometimes mistakenly called concrete pavers or simply pavers. This has led to past misapplication of paving slabs in areas with substantial vehicular loads where interlocking concrete pavers should have been used. While concrete pavers and paving slabs are used in pedestrian applications, slabs are primarily for pedestrian use and limited vehicular traffic. Very large and thick slabs (called mega-slabs or large format paving units) have been used in some urban vehicular



Figure 3. Test specimen from a slab immersed in a 3% saline solution ready for exposure to laboratory freeze-thaw cycles.

applications. A practical, construction-related difference between concrete pavers and paving slabs is the former generally requires one hand to install a unit and the latter requires at least two hands to lift and place.

To emphasize differences in their ability to receive repeated vehicular loads, compare the total number of lifetime 18,000 lb. (80 kN) equivalent single axle loads (ESALs) in the base thickness design tables in *ICPI Tech Spec 4—Structural Design of Interlocking Concrete Pavement* to those in this bulletin. *Tech Spec 4* provides structural designs up to 10 million ESALs whereas the maximum in this bulletin for paving slabs and planks is 30,000 ESALs. This indicates that paving slabs and planks are exposed to limited vehicular traffic, and especially a limited number of trucks.

Types of Finishes

Slab and plank manufacturing methods can include dry cast (zero slump) or wet cast concrete, or hydraulically pressed units. Like concrete pavers, concrete paving slabs can be manufactured with a variety of colors, special aggregates, and architectural finishes to enhance their appearance. Surface finishes include formed, shot-blasted, hammered, polished and tumbled. Blasted finishes are created by rapidly discharging small steel pellets on the surface to create a roughened, stone like appearance. Hammered finishes rely on knurled steel hammers to roughen the surface. Rotating disk grinders create polished surfaces that smooth the surface even to the point where units appear as terrazzo. Architectural finishes typically rely on special aggregates and pigment in the surface that become more pronounced after surface

treatments. All of these finishes provide visually attractive alternatives superior in appearance to many other types of pavement materials. See Figure 4.

Structural Design

Pedestrian Applications—For pedestrian applications, units up to 12 x 12 in. (300 x 300 mm) in length and width can be placed on a minimum 6 in. (150 mm) thickness of compacted aggregate base under a 1 in. (25 mm) thick sand setting bed with jointing sand. Thicker bases (generally 8 to 12 in. or 200 to 300 mm thick) should be used in freezing climates and/or on weak clay soils (CBR < 3%). For units larger than 12 x 12 in., designers should consider using a concrete base because achieving a very smooth, compacted aggregate base surface can be difficult and time consuming. If the paving units are in commercial sand-set or bitumen-set pedestrian applications, they will likely require higher (closer) tolerances than ASTM or CSA product standards require as previously noted. For additional information on bitumen-set applications, read *ICPI Tech Spec 20—Construction of Bituminous-Sand Set Interlocking Concrete Pavement*. “Dry pack” bedding layers consisting of a sand-cement mix on any base are not recommended for pedestrian or vehicular applications. There is little assurance of a consistent sand-cement mix (typically done on the job site). This mixture does not keep out water which can weaken it over time, especially in freezing climates.

Vehicular Applications—A civil engineer should be consulted to assist with structural designs for vehicular applications as noted below.

1. Determine the anticipated traffic use in Table 1. The maximum allowable 18,000 lb (80 kN) equivalent single axle loads or ESALs for paving slabs is 30,000 or a Caltrans Traffic Index (TI) of 6.

2. Determine the soil strength. The minimum values for designs is a resilient modulus of 5,100 psi (35 MPa), 3% California Bearing Ratio, or an R-value = 7. Determine the resilient modulus, M_r , per AASHTO T-307 *Determining the Resilient Modulus of Soils and Aggregate Materials*. Surrogate test methods may be used including ASTM D1883 *Standard Test Method for California Bearing Ratio (CBR) of Laboratory-Compacted Soils*, AASHTO T-193 *The California Bearing Ratio*. The CBR test should be a 96-hour soaked test to represent subgrade strength in its weakest condition. Test methods can include R-Value using ASTM

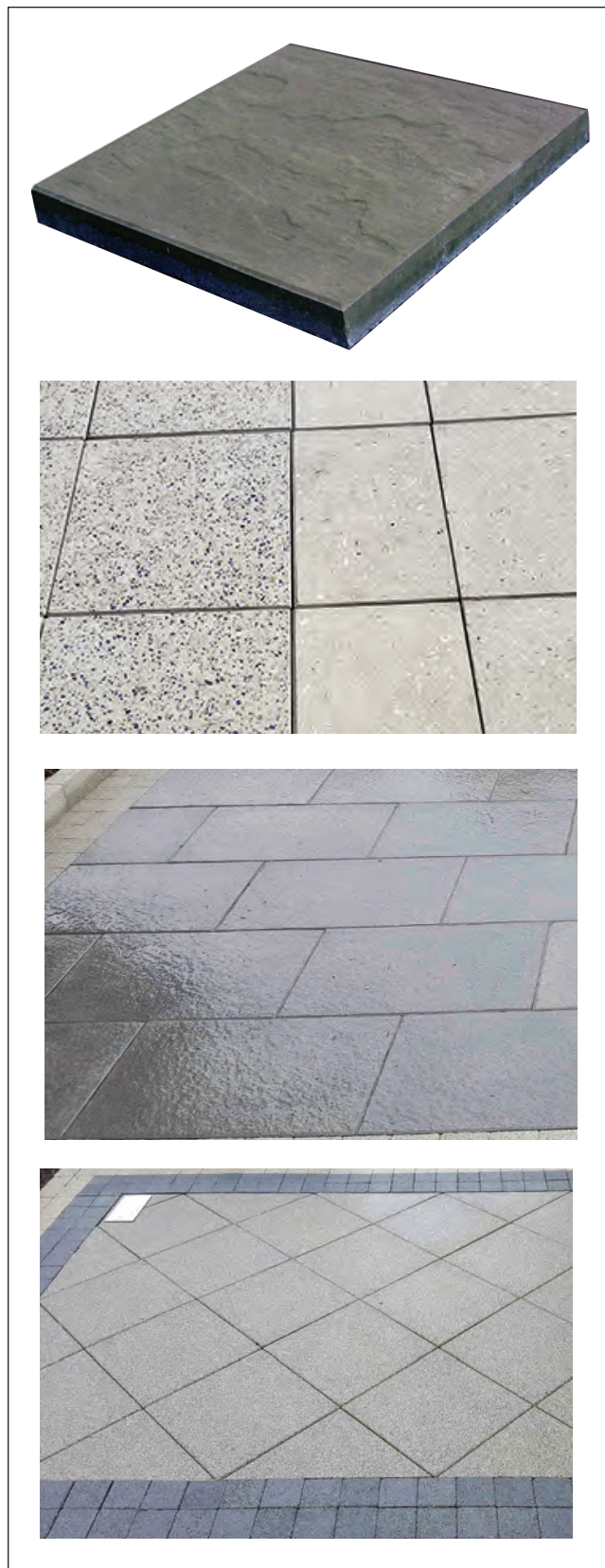

Figure 4. Some examples of paving slab finishes (top to bottom): textured, polished, hammered, and shot blasted.

D2844 *Standard Test Method for Resistance R-Value and Expansion Pressure of Compacted Soils or AASHTO T-190* of the same title. CBR and R-Values are correlated to resilient modulus, M_r , using the equations below:

$$M_r \text{ in psi} = 2,555 \times (\text{CBR})^{0.64} \quad M_r \text{ in MPa} = 17.61 \times \text{CBR}^{0.64}$$

$$M_r \text{ in psi} = 1,155 + 555 \times R \quad M_r \text{ in MPa} = (1,155 + 555 \times R)/145$$

3. **Determine the paving slab length and width.** This may be influenced by architectural design considerations. Such considerations must align with the structural design guidelines in this bulletin. This may require using a smaller and/or thicker unit configuration in some traffic situations. Square units are recommended in vehicular traffic with placement in a running bond pattern. Rectangular units should be subject only to pedestrian traffic.
4. **Select one of two base options.** Tables 2 and 3 correspond to the base options listed below. Note that Tables 2 and 3 apply to units with a minimum flexural strength of 725 psi (5 MPa) required in ASTM C1782 and CSA A231.1.

Base options:

- (a) A 12 in. (300 mm) thick compacted aggregate base whose gradation conforms to provincial, state or municipal specifications for road base used under asphalt pavement. If there are no standards or guidelines, use the gradations in ASTM D2940 *Standard Specification for Graded Aggregate Material for Bases or Subbases for Highways or Airports* and as described in

ICPI Tech Spec 2—Construction of Interlocking Concrete Pavements. Construction should include compacting the soils subgrade and bases/subbases to at least 95% of standard Proctor density per ASTM D698 *Standard Test Methods for Laboratory Compaction of Soil Standard Effort*.

- (b) A 4 in. (100 mm) thick concrete base over a 6 in. (150 mm) compacted aggregate base. The concrete (typically ready-mixed) minimum compressive strength is 3,000 psi (20 MPa) per ASTM C39 *Standard Test Method for Compressive Strength of Cylindrical Concrete Specimens*. Concrete bases are required for bitumen-set applications.
5. **Find the paving slab length, width and thickness in the table that corresponds to the base type selected.** If the paving slab length and width are not in the table, find the next closest with the same length and width or smaller, and the same thickness or thicker.
6. **From the table and slab configuration row selected, go across to intersect the column that best represents the soil characteristics from laboratory testing.** If the exact soil characteristics do not match those in the table, then use the closest lower (conservative) values. Soils with values exceeding those on the tables should not be exposed to higher traffic than as indicated in the tables. In other words, use the configurations under the highest soil subgrade resilient modulus of 11,600 psi (80 MPa), 10% CBR or R-value = 18.

Table 1. Traffic categories and limits

Traffic Limits	Category Symbol	Stress Ratio	Lifetime ESALs** (TI)	Equivalent Heavy Vehicles/Day
Do Not Subject to Vehicles	No	>0.7	0	0
Primarily Pedestrian*	P	0.7	1,000 (4)	0.1
Cars only (< 4500 lbs or 2000 kg)	C	0.5	7,500 (5)	0.5
Cars and Light Trucks (< 10,000 lb or 4500 kg)	LT	0.4	30,000 (6)	2.0

*This includes applications with extremely rare use by emergency vehicles. Maintenance vehicles are not allowed. This traffic category includes residential driveways. Caution: Units larger than 12 x 12 in. (300 mm x 300 mm) may shift under tires.

**ESALs = 18,000 lb (80 kN) equivalent single axle loads.

7. If the traffic category symbol in Table 1 matches the number of ESALS for the anticipated traffic selected, then the selected paving slab configuration may be used.

8. If the traffic category symbol in Table 1 represents a lower number of ESALS for the anticipated traffic selected, then find a traffic limit symbol that matches the original selection by:

- (a) checking another table with a different base;
- (b) select a thicker paving slab, or
- (c) select a smaller paving slab.

9. If the traffic category symbol in Table 1 represents a higher number of ESALS for the anticipated traffic selected, the designer has the option of finding a traffic limit symbol that matches the original selection by:

- (a) checking another table with a different base;
- (b) select a thinner paving slab; or
- (c) select a larger paving slab.

Tables 2 and 3 were developed by Applied Research Associates, Inc. using finite element modeling of a dual truck tire (40 kN or 9,000 lb load) passing over the paving slabs, an inch of bedding sand, and the bases noted on the tables (ARA 2016). Resulting slab stresses were divided by the paving slab flexural strengths noted on the tables to render stress ratios. Low stress ratios were applied to the higher ESALS to reduce the risk of paving slab cracking and higher ratios applied to lower ESAL traffic. Additionally, stress ratios lower than those associated with concrete road pavements were applied to higher ESALS as a conservative design measure because lateral forces from truck tires turning, braking or accelerating were not modeled.

Full-scale load testing was conducted on a limited number of slabs. The slab sizes tested are noted with asterisks on Tables 2 and 3 and the rest developed using finite element modeling. Full-scale load testing was done across a test pad

subject to slowly moving truck traffic with no turning and little braking forces. The slabs on aggregate and concrete bases were subject to 75,000 ESALS with some performing adequately. However, the design tables reflect a 30,000 ESAL limit. This conservative limit is provided because the test pad was not subject to turning and little braking forces which can be significantly higher than wheel loads simply passing over the pavement. (Horr 2022). The designs presented in Tables 2 and 3 are more conservative than those from overseas (CMAA 2000, Interpave 2010, SLG 2013) as well as from performance under full-scale load testing.

Table 2 represents designs for segmental paving slabs set on an inch (25 mm) of bedding sand over 12 in. (300 mm) of compacted aggregate base. Table 3 includes the same 1 in. (25 mm) thick sand setting bed over 4 in. (100 mm) thick concrete base on a 6 in. (150 mm) thick compacted aggregate subbase. Table 3 also applies to structural design of paving slabs in a bitumen-sand bed (typically $\frac{3}{4}$ to 1 in. or 20 to 25 mm thick) since bitumen-set applications require a concrete base. Table 3 applied to bitumen-set applications introduces an additional measure of conservative design since bitumen-sand materials provide a modest increase in stiffness and increased stability resisting repeated turning, accelerating and braking tire lateral loads. See *ICPI Tech Spec 20 Construction of Bituminous-Sand Set Interlocking Concrete Pavement* for construction guidance.

No tables in this Tech Spec apply to mortar-set applications as they are not recommended for vehicular applications.

All design tables are based on the flexural strength of slabs and planks in full contact with the bedding and base beneath. The tables assume bending or flexural strength per ASTM or CSA test methods. Because these tests suspend a paving unit between two rollers, this creates a more concentrated stress condition than applying a wheel load to a paving slab or plank fully supported on its entire bottom area. This difference provides a more conservative approach in the design tables.

Table 2. Traffic load limits for concrete paving slabs on a minimum 12 in. (300 mm) thick aggregate base . No = Do not subject to vehicles; P = Primarily pedestrian; C = Cars only; and LT = Cars and light truck per Table 1.

Paving Slab Length in. (mm)	Paving Slab Width in. (mm)	Paving Slab Thickness in. (mm)	SQUARE PAVING SLABS ON A MINIMUM 12 IN. (300 MM) THICK AGGREGATE BASE			
			Paving Slab Minimum Flexural Strength = 725 psi (5.0 MPa) Subgrade Modulus, PSI (MPa) CBR, R-Value			
			5100 (35) 3%, 7	7200 (50) 5%, 10	8700, (60) 6.8%, 13	11,600 (80) 10%, 18
12 (300)	12 (300)	2 (50)	P	P	P	P
*12 (300)	12 (300)	3 (75)	LT	LT	LT	LT
12 (300)	12 (300)	4 (100)	LT	LT	LT	LT
16 (400)	16 (400)	2 (50)	P	P	P	P
16 (400)	16 (400)	3 (75)	LT	LT	LT	LT
16 (400)	16 (400)	4 (100)	LT	LT	LT	LT
18 (450)	18 (450)	2 (50)	No	No	No	P
18 (450)	18 (450)	3 (75)	C	C	C	C
18 (450)	18 (450)	4 (100)	LT	LT	LT	LT
24 (600)	24 (600)	2 (50)	No	No	No	No
*24 (600)	24 (600)	3 (75)	P	P	P	P
24 (600)	24 (600)	4 (100)	C	C	C	C

*Subject to full-scale load tests

Table 3. Traffic load limits for concrete paving slabs on a minimum 4 in. (100 mm) thick concrete base over a 6 in. (150 mm) thick aggregate subbase . LT = Cars and light trucks per Table 1.

Paving Slab Length in. (mm)	Paving Slab Width in. (mm)	Paving Slab Thickness in. (mm)	SQUARE PAVING SLABS ON A MINIMUM 4 IN. (100 MM) THICK CONCRETE BASE AND 6 IN. (150 MM) THICK AGGREGATE SUBBASE			
			Paving Slab Minimum Flexural Strength = 725 psi (5.0 MPa) Subgrade Modulus, PSI (MPa, CBR, R-Value)			
			5100 (35) 3%, 7	7200 (50) 5%, 10	8700 (60) 6.8%, 13	11,600 (80) 10%, 18
*12 (300) to 24 (600)	12 (300) to 24 (600)	2 (50) to 4 (100)	LT	LT	LT	LT

*12 x 12 x 3.125 in. (300 x 300 x 80 mm) slabs were subject to full-scale load tests.

*24 x 24 x 3.125 in. (600 x 600 x 80 mm) slabs were subject to full-scale load tests.

Concrete Planks

Product Definition—Concrete planks or linear paving units are between 11.75 in. (298 mm) and 48 in. (1200 mm) in length. Their minimum width is 3 in. (75 mm) and maximum width is 6 in. (100 mm). Additionally, their plan ratio, or length divided by width, and aspect ratio, or length divided by thickness, are both equal to or greater than four. Their minimum thickness is 2.36 in. (60 mm). (Tables 4 and 5 start at 3 in. (75 mm) minimum thickness for vehicular applications.) Dimensional tolerances can follow that in ASTM C1782 or CSA A231.1. Planks meeting dimensional tolerances in these standards can be installed on a sand setting bed (i.e., sand-set), but are generally not suitable for bitumen-set applications. This installation method requires length, width, thickness and warpage tolerances not exceeding ± 0.06 in. (± 1.5 mm) than the specified dimensions. In some cases, paving units may require post-production grinding or gauging to achieve these tolerances.

Product Standards in the U.S.—While there is no ASTM standard for planks, the following guidance for product testing and specifications is recommended. Plank units can be tested in flexural strength according to ASTM C1782. They should have an average minimum flexural strength of 725 psi (5 MPa) in order to correspond to the same on Tables 4 and 5. Dimensional tolerances follow C1782. Likewise, freeze-thaw durability requirements should also conform to the mass loss specified in C1782 using test method C1645.

Product Standards in Canada—While there is no CSA standard for planks, the flexural strength testing method CSA A231.1 *Precast Concrete Paving Slabs* is recommended. Planks should have a minimum average flexural strength of 725 psi (5 MPa) in order to correspond to the same on Tables 4 and 5. Dimensional tolerances in A231.1 can be applied to planks as well. Freeze-thaw deicer resistance testing should follow that in CSA A231.1 and meet the mass loss requirements as well.

Plank Structural Design

Pedestrian Applications—For pedestrian applications, units up to 12 in. (300 mm) long can be placed on a 1 in. (25 mm) thick layer of coarse, washed bedding sand conforming over a minimum 6 in. (150 mm) thickness of compacted aggregate base. Thicker bases (generally 8 to 12 in. or 200 to 300 mm thick) should be used in freezing climates and/or on weak clay soils (CBR < 3%). For paving units over 12 in. (300 mm) long on a 1 in. (25 mm) thick sand setting bed, a minimum 4 in. (100 mm) thick concrete base on a 6 in. (150 mm)

thick aggregate subbase should be considered. Compacted aggregate bases should not be used with paving units longer than 12 in. (300 mm) due to the difficulty of creating a smooth base surface to accommodate bedding sand.

If the planks are bitumen-set for pedestrian or vehicular applications, higher (closer) dimensional tolerances than those noted under Product Definition are recommended, i.e., ± 0.12 in. or ± 1.5 mm for length, width, height, and warpage. Bitumen-set units should be set on a concrete base regardless of their length. For additional information on bitumen-set applications, read *ICPI Tech Spec 20—Construction of Bituminous-Sand Set Interlocking Concrete Pavement*.

Structural Design Steps for Planks in Vehicular Applications

- 1. Determine the anticipated traffic use in Table 1.**
The maximum allowable 18,000 lb (80 kN) equivalent single axle loads or ESALs for planks is 30,000 or a Caltrans Traffic Index (TI) of 6.
- 2. Determine the soil strength.** As with concrete paving slabs, planks in vehicular applications should not be subject to resilient modulus values lower than 5,100 psi (35 MPa), 3% California Bearing Ratio, or an R-value = 7. The recommendations for soil testing for concrete paving slabs also apply to concrete planks.
- 3. Determine the plank length, width and thickness.** This may be influenced by architectural design considerations. Such considerations must align with the design guidelines in this bulletin. This may require using a different unit configuration. Shorter, thicker units are recommended over longer ones in vehicular traffic.
- 4. Select one of two base options.** Tables 4 and 5 correspond to the base options listed below. Two base options presented for supporting planks are the same as those for concrete paving slabs:
 - (a) A 12 in. (300 mm) thick compacted aggregate base.
 - (b) A 4 in. (100 mm) thick concrete base over a 6 in. (150 mm) compacted aggregate base. This option is required when using bitumen-set planks.
- 5. Find the plank length and width and thickness in the table that corresponds to the base type selected.** If the plank length, width, and thickness are not in the table, find the closest with the same length and width or smaller, and the same thickness or thicker.

- 6. From the table and slab configuration row selected, go across to intersect the column that best represents the soil characteristics from laboratory testing.** If the exact soil characteristics do not match those in the table, then use the closest lower (conservative) values. If the soil subgrade strength is higher and does not appear in the table, use the slab configurations under the highest soil subgrade resilient modulus of 11,600 psi (80 MPa), 10% CBR or R-value = 18.
- 7. If the traffic limit symbol matches the ESALs of the anticipated traffic selected, then the selected plank length, width and thickness can be used.**
- 8. If the traffic category symbol in Table 1 represents a lower number of ESALs for the anticipated traffic selected, then find a traffic limit symbol that matches the original selection by:**
 - (a) checking another table with a different base;
 - (b) select a thicker plank, or
 - (c) select a smaller (shorter) plank.
- 9. If the traffic category symbol in Table 1 represents a higher number of ESALs for the anticipated traffic selected, then find a traffic limit symbol that matches the original selection by:**
 - (a) checking another table with a different base;
 - (b) select a thinner plank; or
 - (c) select a longer plank.

Like the tables for paving slabs, Tables 4 and 5 were developed using finite element modeling of a dual truck tire passing over the planks, an inch of bedding sand, and various bases noted on the tables (ARA 2016). Stresses recorded were divided by the flexural strength of a 725 psi (5 MPa) plank slab to render stress ratios. Low stress ratios were applied to the higher ESALs to reduce the risk of a plank cracking and higher ratios applied to lower ESAL traffic. Additionally, low stress ratios were applied to higher ESALs as a conservative design measure because lateral forces from truck tires from turning, braking or accelerating were not modeled.

Limited full-scale testing was conducted on a few plank sizes. These plank sizes are noted with asterisks on Tables 4 and 5 and the rest developed using finite element modeling. As previously noted, the planks on aggregate and concrete bases were subject to 75,000 ESALs with some performing adequately. However, the design tables reflect a 30,000 ESAL limit. This conservative limit is provided because the test pad was not subject to turning and little braking forces which can be significantly higher than wheel loads simply passing over the pavement. (Horr 2022). Therefore, Tables 4 and 5 represent conservative designs using the finite element modeling by Applied Research Associates, Inc. for concrete planks set on an inch (25 mm) of bedding sand. Table 5 using a concrete base applies to sand-set and bitumen-set applications since a concrete base is required for the latter.

Table 4. Traffic load limits for concrete planks on a minimum 12 in. (300 mm) aggregate base. P = Primarily pedestrian use; C = Cars only; and LT = Cars and light trucks per Table 1.

Plank Length in. (mm)	Plank Width in. (mm)	Plank Thickness in. (mm)	CONCRETE PLANKS ON A MINIMUM 12 IN. (300 MM) AGGREGATE BASE			
			Paving Minimum Flexural Strength = 725 psi (5.0 MPa) Subgrade Modulus, PSI (MPa) CBR, R-Value			
			5100 (35) 3%, 7	7200 (50) 5%, 10	8700 (60) 6.8%, 13	11600 (80) 10%, 18
12 (300)	3 (75)	3 (75)	C	C	C	C
12 (300)	3 (75)	4 (100)	LT	LT	LT	LT
12 (300)	4 (100)	3 (75)	C	C	C	LT
*12 (300)	4 (100)	4 (100)	LT	LT	LT	LT
12 (300)	5 (125)	3 (75)	LT	LT	LT	LT
12 (300)	5 (125)	4 (100)	LT	LT	LT	LT
12 (300)	6 (150)	3 (75)	LT	LT	LT	LT
12 (300)	6 (150)	4 (100)	LT	LT	LT	LT
18 (450)	3 (75)	3 (75)	P	P	P	P
18 (450)	3 (75)	4 (100)	C	C	C	C
18 (450)	4 (100)	3 (75)	P	P	P	P
18 (450)	4 (100)	4 (100)	C	C	C	C
18 (450)	5 (125)	3 (75)	P	P	P	P
18 (450)	5 (125)	4 (100)	C	C	C	LT
18 (450)	6 (150)	3 (75)	P	P	P	P
18 (450)	6 (150)	4 (100)	C	C	LT	LT
24 (600)	3 (75)	3 (75)	P	P	P	P
24 (600)	3 (75)	4 (100)	P	P	P	P
24 (600)	4 (100)	3 (75)	P	P	P	P
24 (600)	4 (100)	4 (100)	C	C	C	C
24 (600)	5 (125)	3 (75)	P	P	P	P
24 (600)	5 (125)	4 (100)	C	C	C	C

Note: 16 x 4 x 4 in. (400 x 100 x 100 mm) units were subject to full-scale tests can be rated suitable for C traffic.

*Subject to full-scale load tests

Table 4 continued on next page

Table 4. Traffic load limits for concrete planks on a minimum 12 in. (300 mm) aggregate base (continued) . P = Primarily pedestrian use; C = Cars only; and LT = Cars and light trucks per Table 1.

Plank Length in. (mm)	Plank Width in. (mm)	Plank Thickness in. (mm)	CONCRETE PLANKS ON A MINIMUM 12 IN. (300 MM) AGGREGATE BASE			
			Paving Minimum Flexural Strength = 725 psi (5.0 MPa) Subgrade Modulus, PSI (MPa) CBR, R-Value			
			5100 (35) 3%, 7	7200 (50) 5%, 10	8700 (60) 6.8%, 13	11600 (80) 10%, 18
24 (600)	6 (150)	3 (75)	P	P	P	P
24 (600)	6 (150)	4 (100)	C	C	C	C
30 (750)	3 (75)	3 (75)	P	P	P	P
30 (750)	3 (75)	4 (100)	P	P	P	C
30 (750)	4 (100)	3 (75)	P	P	P	P
30 (750)	4 (100)	4 (100)	C	C	C	C
30 (750)	5 (125)	3 (75)	P	P	P	P
30 (750)	5 (125)	4 (100)	C	C	C	C
30 (750)	6 (150)	3 (75)	P	P	P	P
30 (750)	6 (150)	4 (100)	C	C	C	C
36 (900)	3 (75)	3 (75)	P	P	P	P
36 (900)	3 (75)	4 (100)	C	C	C	C
36 (900)	4 (100)	3 (75)	P	P	P	C
36 (900)	4 (100)	4 (100)	C	C	C	C
36 (900)	5 (125)	3 (75)	P	P	P	P
36 (900)	5 (125)	4 (100)	C	C	C	C
36 (900)	6 (150)	3 (75)	P	P	P	P
36 (900)	6 (150)	4 (100)	C	C	C	C

Table 5. Traffic load limits for concrete Planks on a minimum 4 in. (100 mm) concrete base and 6 in. (150 mm) aggregate subbase LT = Cars and light trucks per Table 1.

Plank Length in. (mm)	Plank Width in. (mm)	Plank Thickness in. (mm)	CONCRETE PLANKS ON A MINIMUM 4 IN. (100 MM) CONCRETE BASE AND 6 IN. (150 MM) AGGREGATE SUBBASE			
			Paving Minimum Flexural Strength = 725 psi (5.0 MPa) Subgrade Modulus, PSI (MPa) CBR, R-Value			
			5100 (35) 3%, 7	7200 (50) 5%, 10	8700 (60) 6.8%, 13	11,600 (80) 10%, 18
*12 (300) to 36 (900)	3 (75) to 6 (150)	3 (75) to 4 (100)	LT	LT	LT	LT

*12 x 4 x 4 in. (300 x 100 x 100 mm) units and 16 x 4 x 4 in. (400 x 100 x 100 mm) units subject to full-scale tests can be rated suitable for LT traffic.

References

AASHTO T-190 Standard Method of Test for Resistance R-Value and Expansion Pressure of Compacted Soils, *Standard Specifications for Transportation Materials and Methods of Sampling and Testing*, American Association of State Highway and Transportation Officials, Washington, DC, 2014.

AASHTO T-193 Standard Method of Test for The California Bearing Ratio, *Standard Specifications for Transportation Materials and Methods of Sampling and Testing*, American Association of State Highway and Transportation Officials, Washington, DC, 2013.

AASHTO T-307 Standard Method of Test for Determining the Resilient Modulus of Soils and Aggregate Materials, *Standard Specifications for Transportation Materials and Methods of Sampling and Testing* American Association of State Highway and Transportation Officials, Washington, DC, 1999.

ARA 2016. Hein, D.K., *Segmental Concrete Paving Finite Element Modelling, and Design Charts*, Applied Research Associates, Inc., ARA Project 002486, Toronto, Ontario, Canada, May 2016.

ASTM C39 Standard Test Method for Compressive Strength of Cylindrical Concrete Specimens, Vol. 4.02, *ASTM Annual Book of Standards*, American Society for Testing and Materials International, Conshohocken, Pennsylvania, 2016.

ASTM C936 Standard Specification for Solid Concrete Interlocking Paving Units, Vol. 4.05, *ASTM Annual Book of Standards*, American Society for Testing and Materials International, Conshohocken, Pennsylvania, 2016.

ASTM C1645 Standard Test Method for Freeze-thaw and De-icing Salt Durability of Solid Concrete Interlocking Paving Units Vol. 4.05, *ASTM Annual Book of Standards*, American Society for Testing and Materials International, Conshohocken, Pennsylvania, 2016.

ASTM C1782 Standard Specification for Utility Segmental Concrete Paving Slabs, Vol. 4.05, *ASTM Annual Book of Standards*, American Society for Testing and Materials International, Conshohocken, Pennsylvania, 2016.

ASTM D698 Standard Test Methods for Laboratory Compaction Characteristics of Soil Using Standard Effort (12 400 ft-lbf/ft³ (600 kN-m/m³)), Vol. 4.08, *ASTM Annual Book of Standards*, American Society for Testing and Materials International, Conshohocken, Pennsylvania, 2012.

ASTM D1633 Standard Test Methods for Compressive Strength of Molded Soil-Cement Cylinders, Vol. 4.08, *ASTM Annual Book of Standards*, American Society for Testing and Materials International, Conshohocken, Pennsylvania, 2007.

ASTM D1883 Standard Test Method for California Bearing Ratio (CBR) of Laboratory-Compacted Soils, American Society for Testing and Materials International, Vol. 4.08, *ASTM Annual Book of Standards*, American Society for Testing and Materials International, Conshohocken, Pennsylvania, 2016.

ASTM D2844 Standard Test Method for Resistance R-Value and Expansion Pressure of Compacted Soils, Vol. 4.08, *ASTM Annual Book of Standards*, American Society for Testing and Materials International, Conshohocken, Pennsylvania, 2013.

ASTM D2940, Standard Specification for Graded Aggregate Material for Bases or Subbases for Highways or Airports, Vol. 4.03, *ASTM Annual Book of Standards*, American Society for Testing and Materials International, Conshohocken, Pennsylvania, 2015.

CMAA 2000. *Concrete Flag Pavements Design and Construction Guide*. MA44, Concrete Masonry Association of Australia, Sydney, Australia.

CSA A231.1, *Precast Concrete Paving Slabs*, Canadian Standards Association, Rexdale, Ontario, 2019.

CSA A231.2, *Precast Concrete Pavers*, Canadian Standards Association, Rexdale, Ontario, 2019

Horr 2022. Horr, W. B. and Smith, D. R., *Performance Evaluation Report of the Paving Slab & Plank Full-Scale Testing*. Interlocking Concrete Pavement Institute, Chantilly, VA.

ICPI Tech Spec 2—Construction of Interlocking Concrete Pavements, Interlocking Concrete Pavement Institute, Chantilly, Virginia, 1995.

ICPI Tech Spec 4—Structural Design of Interlocking Concrete Pavements, Interlocking Concrete Pavement Institute, Chantilly, Virginia, 1995.

ICPI Tech Spec 14—Segmental Concrete Paving Units for Roof Decks. Interlocking Concrete Pavement Institute, Chantilly, Virginia, 2002.

ICPI Tech Spec 20—Construction of Bituminous-Sand Set Interlocking Concrete Pavement, Interlocking Concrete Pavement Institute, Chantilly, Virginia, 2014.

Interpave 2010. *Concrete Flag Paving*. The Precast Concrete Paving & Kerb Association, Leicester, England.

SLG 2013. *Planungleitfaden* (Planning guide), Plattenbeläge aus Beton für befahrene Verkehrsflächen (Concrete Paving Slabs for Busy Vehicular Traffic Areas), Betonverband Strasse, Landschaft, Garten, e.V. (Concrete Association for Street, Landscape and Garden), Bonn, Germany.



Interlocking Concrete
Pavement Institute®

14801 Murdock Street
Suite 230
Chantilly, VA 20151

In Canada:
P.O. Box 1150
Uxbridge, ON L9P 1N4
Canada

Tel: 703.657.6900
Fax: 703.657.6901
E-mail: icpi@icpi.org
www.icpi.org

The content of ICPI Tech Spec technical bulletins is intended for use only as a guideline. It is not intended for use or reliance upon as an industry standard, certification or as a specification. ICPI makes no promises, representations or warranties of any kind, expressed or implied, as to the content of the Tech Spec Technical Bulletins and disclaims any liability for damages resulting from the use of Tech Spec Technical Bulletins. Professional assistance should be sought with respect to the design, specifications and construction of each project.

BOD Approved: xxxxxx xx, 2021