

*Note: OFS MODELS PROVIDE FOR 2' OF MASONRY CHIMNEY (NOT SHOWN)

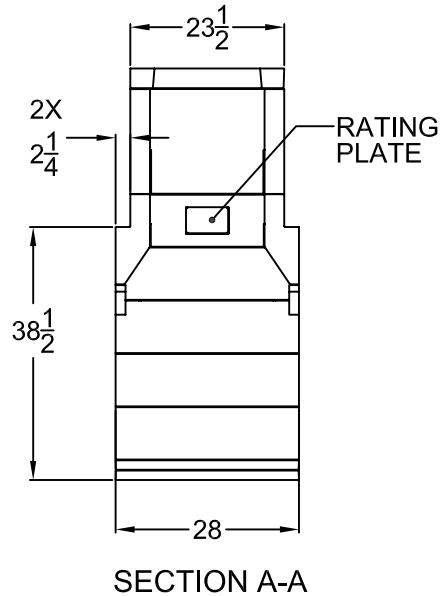
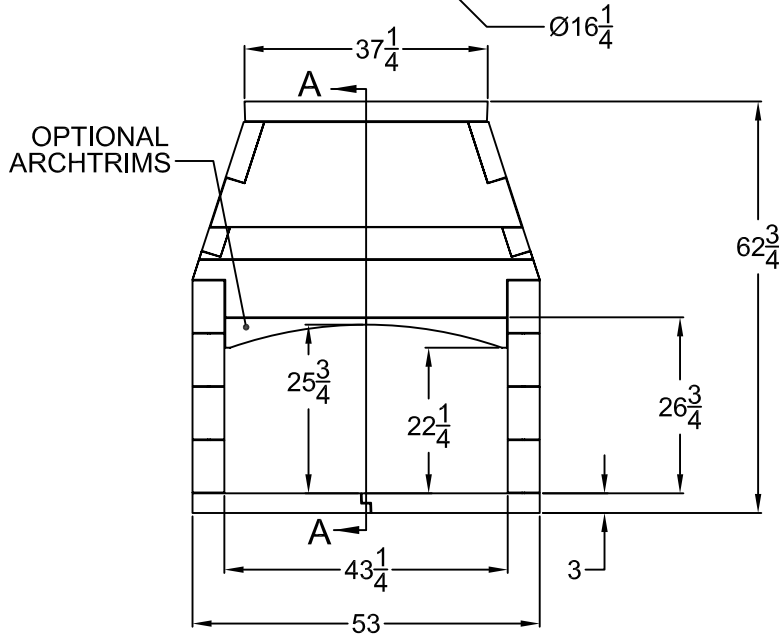

OTHER DIMENSIONS	
Framing Width	57"
Framing Height	65"
Framing Depth	28"
Flue Size - Class A	Ø16"
Fireplace Weight	1,542 lbs
Damper/Anchor Plate, Firebrick, Grout & Mortar	350 lbs
Steel Platform Weight	70 lbs
Max Chimney Weight	10 lbs/lineal ft.

ACCESSORIES	
Herringbone Brick Liner	FBK44SHB
Full Running Bond Brick Liner	FBK44FHB
Structural Metal Base Kit - 8"	BK44SHB
Anchor Plate/Damper	AP-AC14
Combustion Air Kit	BFP4-AK
Masonry Arch	BFP-ARC44

TITLE: OFS/TFS43-ST SEE-THRU FIREPLACE			
DWG. NUMBER	RELEASE DATE	REV. DATE	APPROVED
ST-01	04/10/11		MF